

FOR NOT SPECIFIED  
TIGHTENING TORQUES  
SEE NPF 086

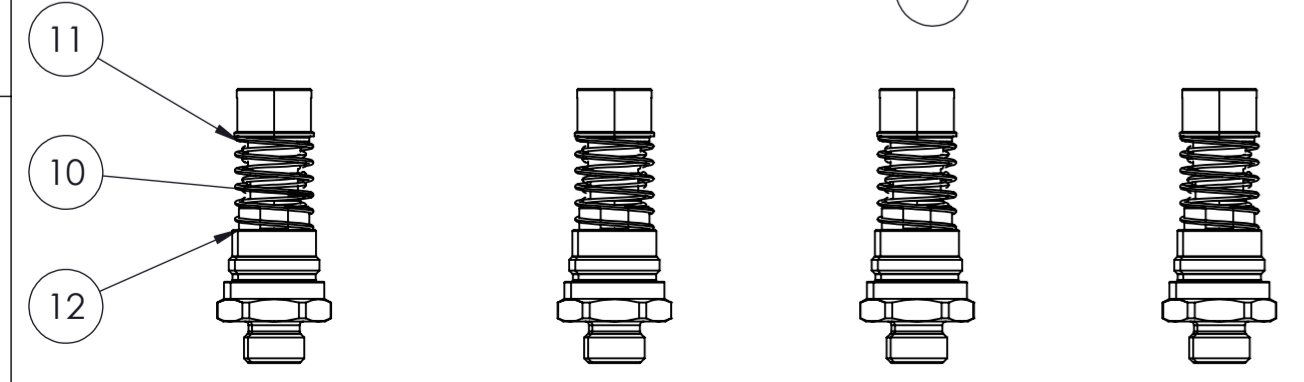
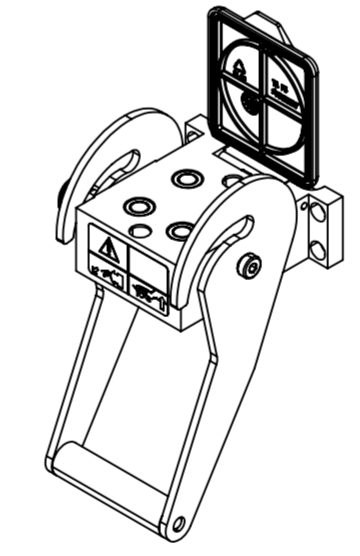
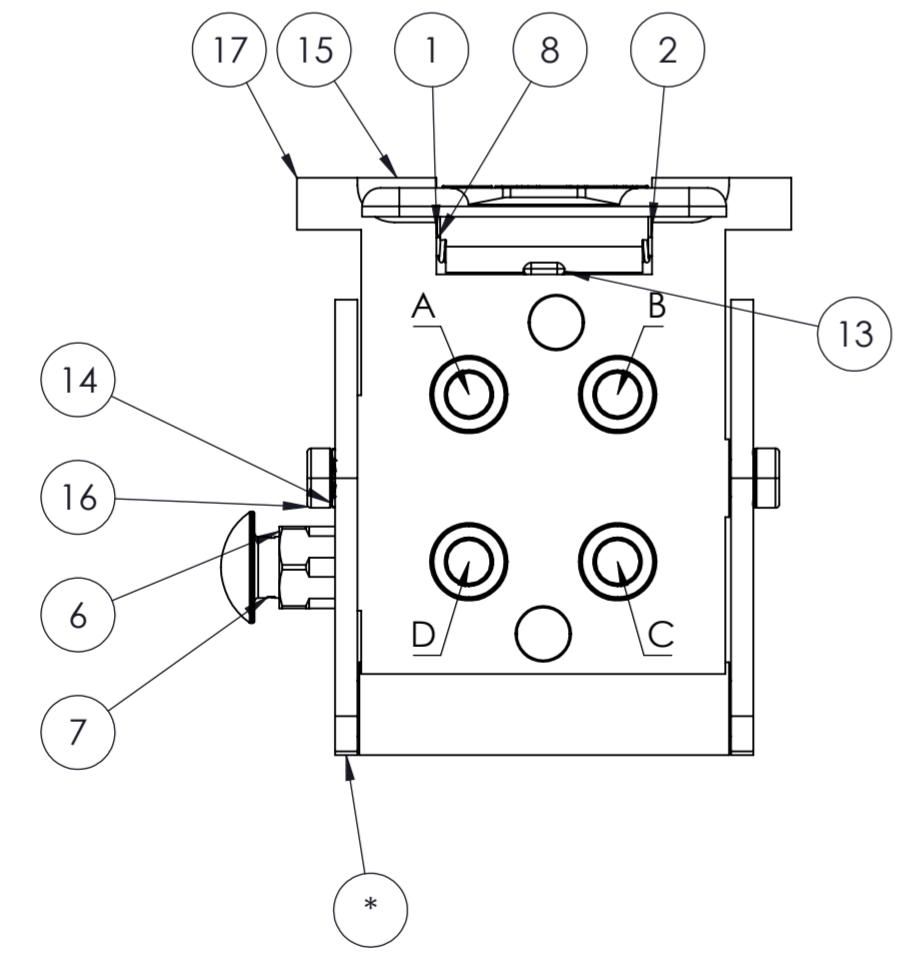
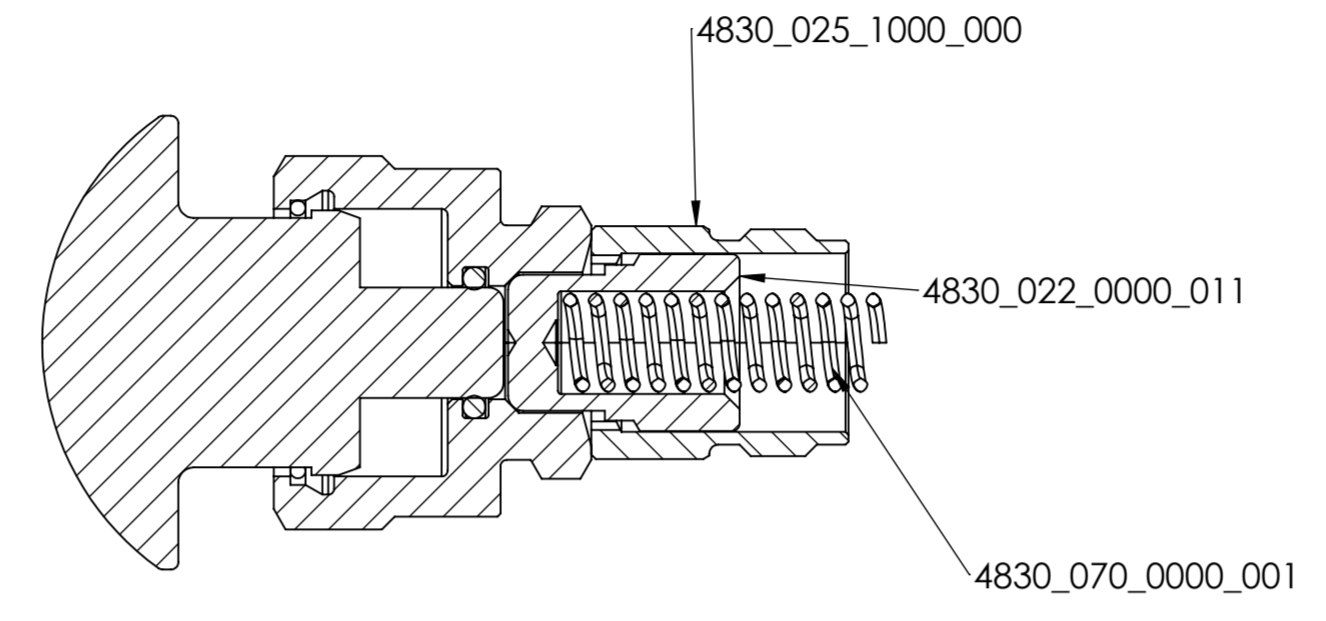
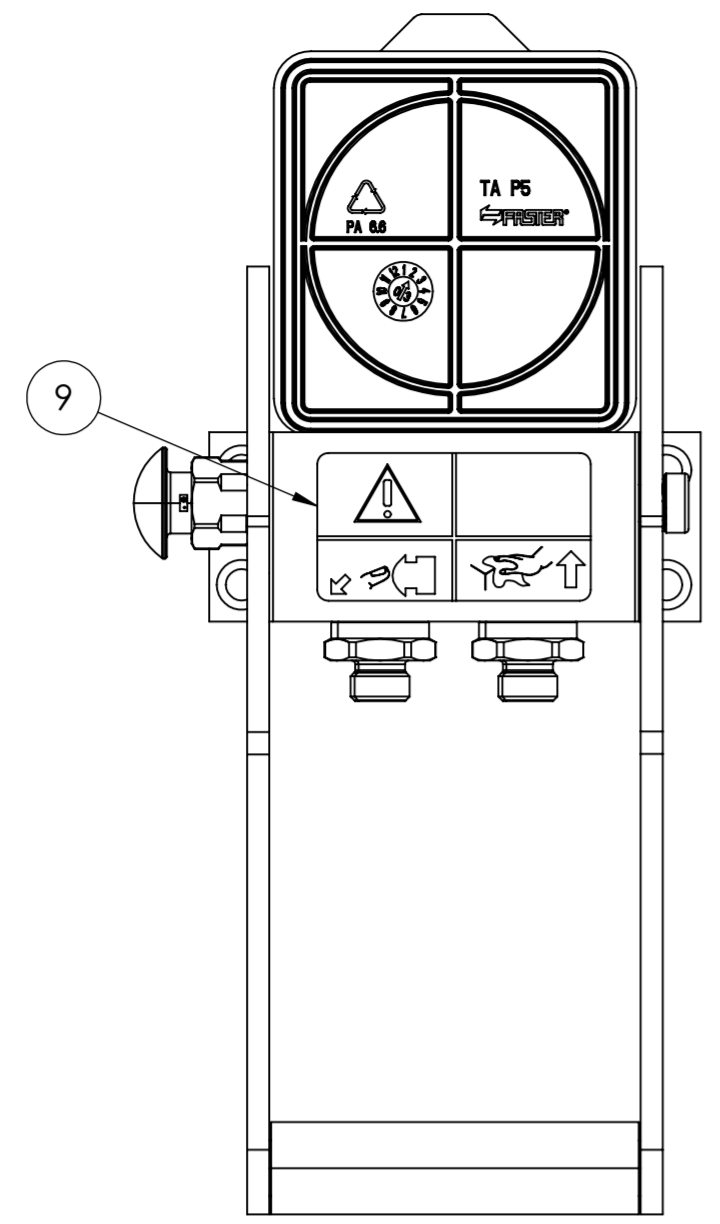

POS.	Q.TY	DESCRIPTION	DRAWING N°	HEX
17	1	ASSIEME LEVA P506 SIC SX	48300240003000	
16	2	VITE M8X20,5 DEFORMATA A FREDDO	48300133000020	
15	1	PIASTRA FISSA P506F A 4 FEMMINE X B	48300200000002	
14	2	ANELLO DI COMPENSAZIONE	00483171000000	
13	1	TAPPO MULTIFASTER P506	48100010001014	
12	4	GRUPPO INTERNO 06 PER PIASTRA	2FFNB38-2/16 F	27
11	4	CURSORE ESTERNO 2FFNB38 ACCIAIO	41320140000000	
10	4	MOLLA CURSORE ESTERNO FFH 06	41320720000300	
9	1	STICKER MULTIFASTER SICURA SX	ET011	
8	1	SPINA X TAPPO AUTOMATICO P2	48200010004000	
7	1	PULS SIC DELRIN ROSSO UV RES NEW	48300252000000	
6	1	SICURA NUOVA X PIASTRA P5, ECC.	SICURA P5	
5	1	MOLLA SICURA PIASTRE P5	48300700000001	
4	1	NOTTOLINO SICURA P5 STAMPATO A FREDDO	48300220000011	
3	1	BOCCOLA X NOTTOLINO SICURA P5	48300251000000	
2	1	MOLLA DESTRA X SUPPORTI/PB06 AISI	48300010005301	
1	1	MOLLA SINISTRA X SUPPORTI/PB06 AISI	48300010005300	

**Faster**

RIVOLTA D'ADDA-CR-ITALY

THIS DRAWING IS EXCLUSIVE PROPERTY OF FASTER S.p.A  
ANY UNAUTHORIZED COPY AND/OR USE ARE STRICTLY PROHIBITED.

DRAWN	CONFIGURATOR	GENERAL TOLERANCES (UNLESS OTHERWISE SPECIFIED): LINEAR DIMENSIONS '0.1 ANGULAR DIMENSIONS '1± RADIUS AND CHAMFER '0.05 SHARP EDGES NOT DIMENSIONED; RADIUS OR CHAMFER MAX. 0.2		DESCRIPTION	MULTIFASTER FIXED PART
DATE	26/05/2026			PART NUMBER :	MF-P506 F-003854-F
SIZE	A2	DIMENSION	SYMBOL		
	DIM. MILLIMETERS	CRITICAL			
		IMPORTANT		DRAWING N°	REVISION
		SECONDARY	NO SYMBOL	DB_MF-P506 F-003854-F	A 10