

FOR NOT SPECIFIED
TIGHTENING TORQUES
SEE NPF 086

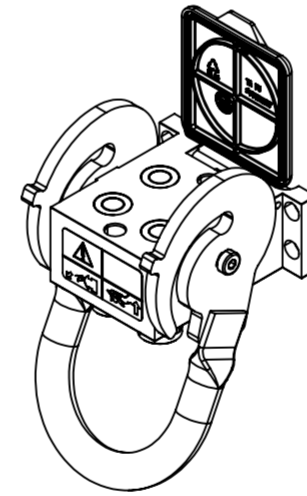

POS.	Q.TY	DESCRIPTION	DRAWING N°	HEX
17	1	ASSIEME LEVE P506-1 CORTA SIC SX	48300244001000	
16	4	FEMM.X BLOCCO 2FFNB12 VIT.INOX	2FFNB12GAS F2V	30
15	4	CURSORE ESTERNO 2FFNB12 AISI 316	43400140000200	
14	1	PIASTRA FISSA P508F A 4 FEMMINE X B	48300200000022	
13	2	ANELLO DI COMPENSAZIONE	00483171000000	
12	1	TAPPO MULTIFASTER P506	48100010001014	
11	2	VITE M8X30,5 DEFORMATA A FREDDO	48300133000030	
10	4	MOLLA CURSORE ESTERNO 2FFN12.F AI	41420721000300	
9	1	STICKER MULTIFASTER SICURA SX	ET011	
8	1	SPINA X TAPPO AUTOMATICO P2	48200010004000	
7	1	PULS SIC DELRIN ROSSO UV RES NEW	48300252000000	
6	1	SICURA NUOVA X PIASTRA P5, ECC.	SICURA P5	
5	2	MOLLA SICURA PIASTRE P5	48300700000001	
4	2	NOTTOLINO SICURA P5 STAMPATO A FREDDO	48300220000011	
3	2	BOCCOLA X NOTTOLINO SICURA P5	48300251000000	
2	1	MOLLA DESTRA X SUPPORTI/PB06 AISI	48300010005301	
1	1	MOLLA SINISTRA X SUPPORTI/PB06 AISI	48300010005300	

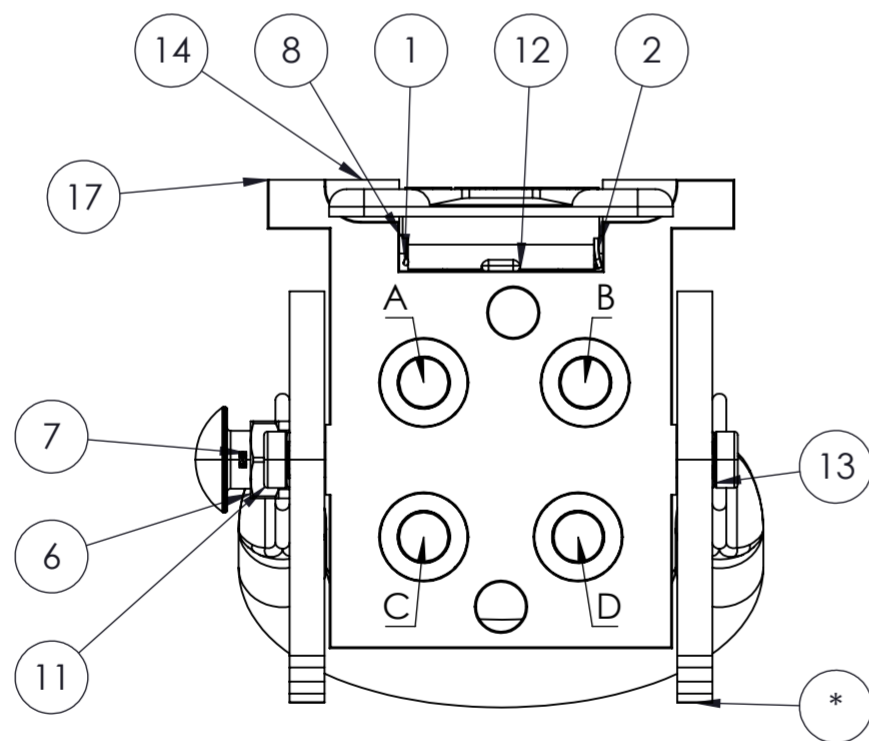
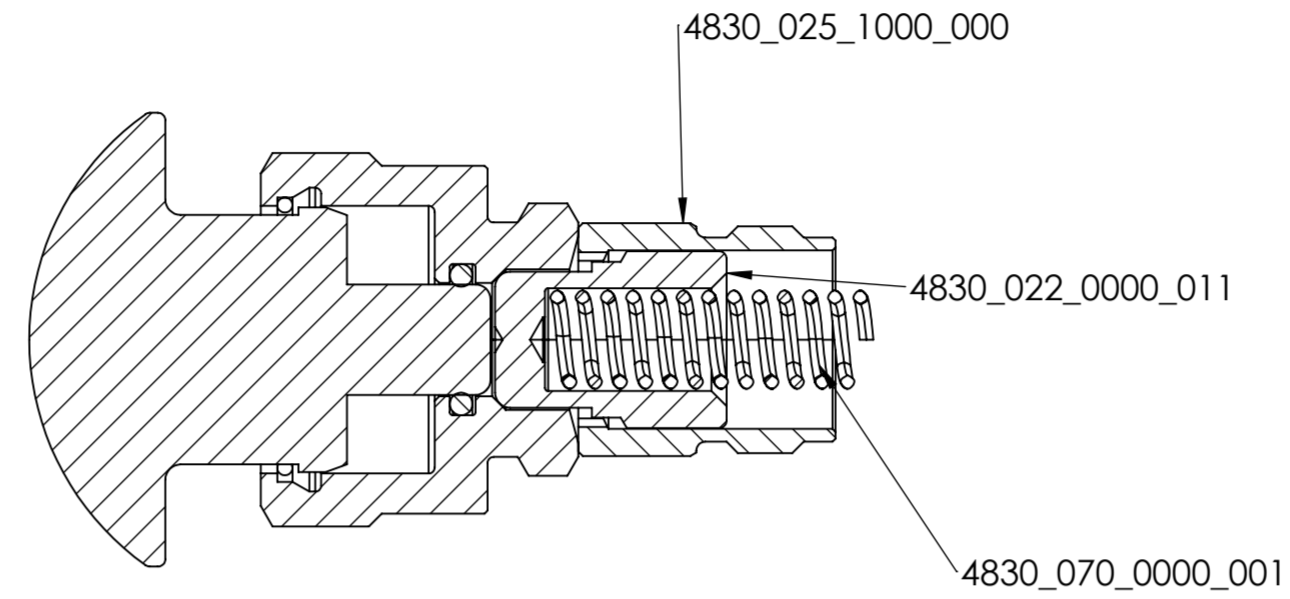
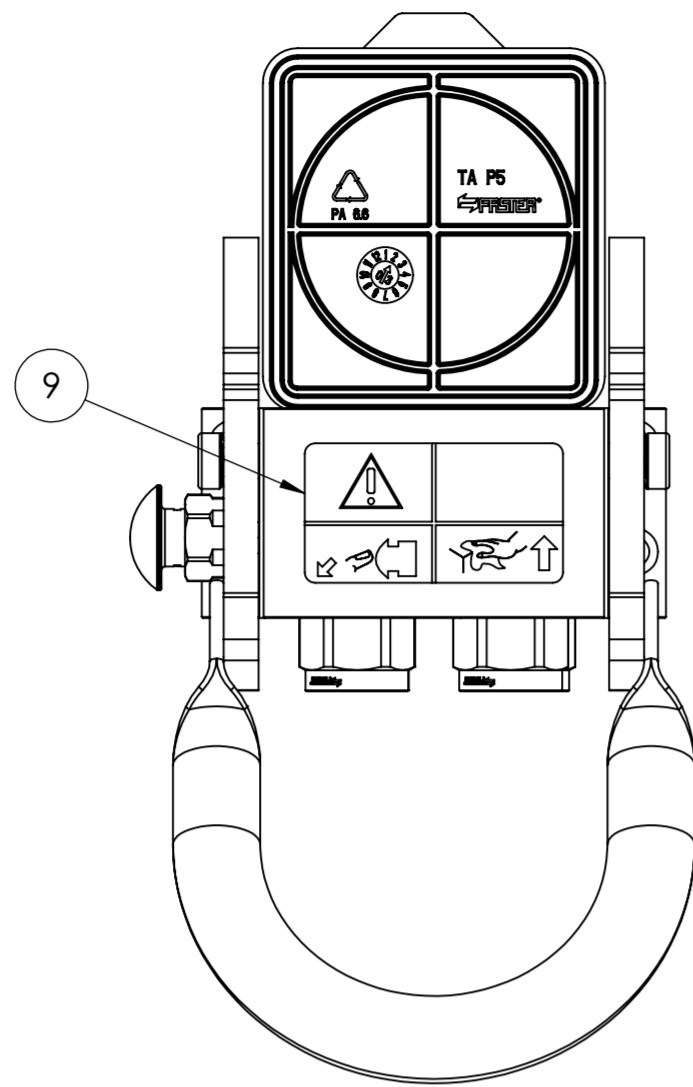
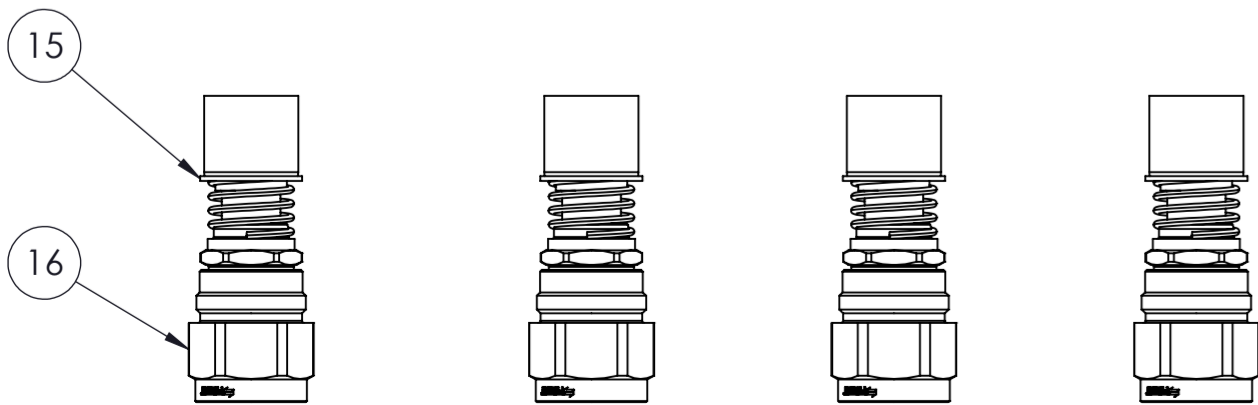

Faster

RIVOLTA D'ADDA-CR-ITALY

THIS DRAWING IS EXCLUSIVE PROPERTY OF FASTER S.p.A
ANY UNAUTHORIZED COPY AND/OR USE ARE STRICTLY PROHIBITED.

DRAWN		GENERAL TOLERANCES (UNLESS OTHERWISE SPECIFIED): LINEAR DIMENSIONS '0.1' ANGULAR DIMENSIONS '1+' RADIUS AND CHAMFER '0.05' SHARP EDGES NOT DIMENSIONED; RADIUS OR CHAMFER MAX. 0.2		DESCRIPTION
DATE	30/01/2025	MULTIFASTER FIXED PART		
SIZE	A2	DIMENSION	SYMBOL	PART NUMBER :
	DIM. MILLIMETERS	CRITICAL	⊕	MF-P508 V F-005809-F
		IMPORTANT	⊕	DRAWING N°
		SECONDARY	NO SYMBOL	DB_MF-P508 V F-005809-F
				REVISION
				A 10

A

B

C

D

E

F

G

H

1

2

3

4

5

8

9

10

11

12