

FOR NOT SPECIFIED
TIGHTENING TORQUES
SEE NPF 086

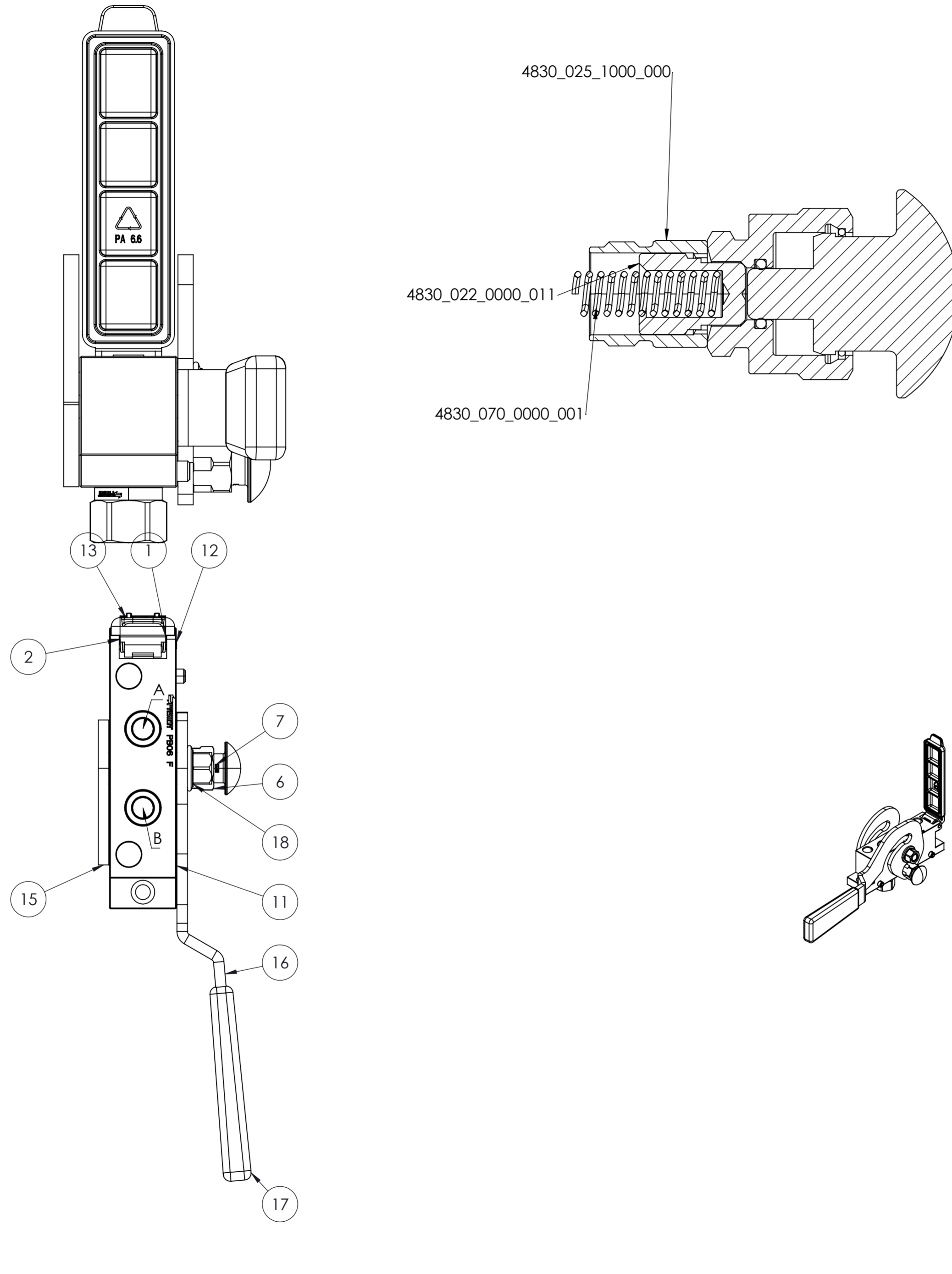

| POS. | Q.TY | DESCRIPTION | DRAWING N° | HEX |
|------|------|---------------------------------------|----------------|-----|
| 18 | 1 | DADO AUTOBLOCCANTE M12 ISO 7044 | 15400800012000 | |
| 17 | 1 | MANOPOLA PVC THENAR MOD.1010 30X6 | 48600240000012 | |
| 16 | 1 | CAMMA SINISTRA X LEVA PB06 INVERTIT | 48600240001011 | |
| 15 | 1 | ASSIEME CAMMA-ALB X PB06 INVERTITA | 48600240001001 | |
| 14 | 2 | DISTANZIALE PTFE PB06 | 48500301000000 | |
| 13 | 1 | TAPPO MULTIFASTER PB06 | 48600010001000 | |
| 12 | 1 | SPINA X TAPPO AUTOMATICO PB06 | 48600010003000 | |
| 11 | 1 | PIASTRA ASSIEME.FIS.INVERT.PB06+GRANI | 48600200001003 | |
| 10 | 2 | GRUPPO INTERNO 06 PER PIASTRA | 2FFNB38 GAS F | 27 |
| 9 | 2 | CURSORE ESTERNO 2FFNB38 ACCIAIO | 41320140000000 | |
| 8 | 2 | MOLLA CURSORE ESTERNO FFH 06 | 41320720000300 | |
| 7 | 1 | PULS SIC DELRIN ROSSO UV RES NEW | 48300252000000 | |
| 6 | 1 | SICURA NUOVA X PIASTRA P5, ECC. | SICURA P5 | |
| 5 | 1 | MOLLA SICURA PIASTRE P5 | 48300700000001 | |
| 4 | 1 | NOTTOLINO SICURA P5 STAMPATO A FREDDO | 48300220000011 | |
| 3 | 1 | BOCCOLA X NOTTOLINO SICURA P5 | 48300251000000 | |
| 2 | 1 | MOLLA DESTRA X SUPPORTI/PB06 AISI | 48300010005301 | |
| 1 | 1 | MOLLA SINISTRA X SUPPORTI/PB06 AISI | 48300010005300 | |
| POS. | Q.TY | DESCRIPTION | DRAWING N° | HEX |

Faster

RIVOLTA D'ADDA-CR-ITALY

THIS DRAWING IS EXCLUSIVE PROPERTY OF FASTER S.p.A
ANY UNAUTHORIZED COPY AND/OR USE ARE STRICTLY PROHIBITED.

| | | | | | |
|-------|------------------|------------------------------------------------------------------------------------------------------------------------------------------------------------------------------------------------------|-----------|------------------------|------------------------|
| DRAWN | CONFIGURATOR | GENERAL TOLERANCES (UNLESS OTHERWISE SPECIFIED): LINEAR DIMENSIONS: ±0.1 ANGULAR DIMENSIONS: ±1° RADIUS AND CHAMFER: ±0.05 SHARP EDGES NOT DIMENSIONED; RADIUS OR CHAMFER MAX. 0.2 | | DESCRIPTION | MULTIFASTER FIXED PART |
| DATE | 23/09/2024 | | | PART NUMBER: | MF-PB06 FD-005379-F |
| SIZE | A2 | DIMENSION | SYMBOL | | |
| | DIM. MILLIMETERS | CRITICAL | | | |
| | | IMPORTANT | | DRAWING N° | REVISION |
| | | SECONDARY | NO SYMBOL | DB_MF-PB06 FD-005379-F | A 10 |