

FOR NOT SPECIFIED  
TIGHTENING TORQUES  
SEE NPF 086

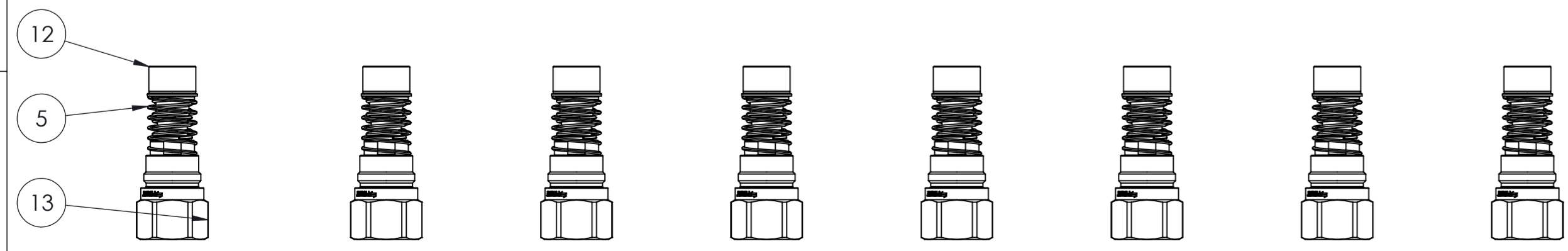
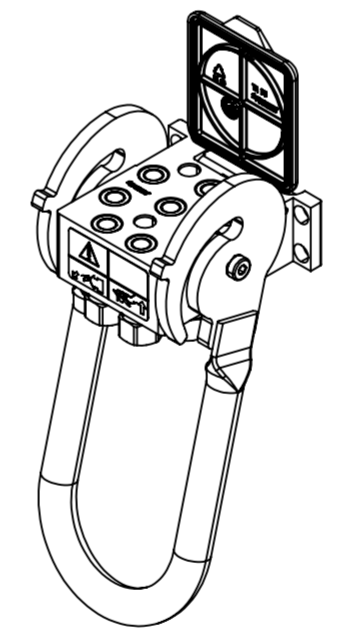
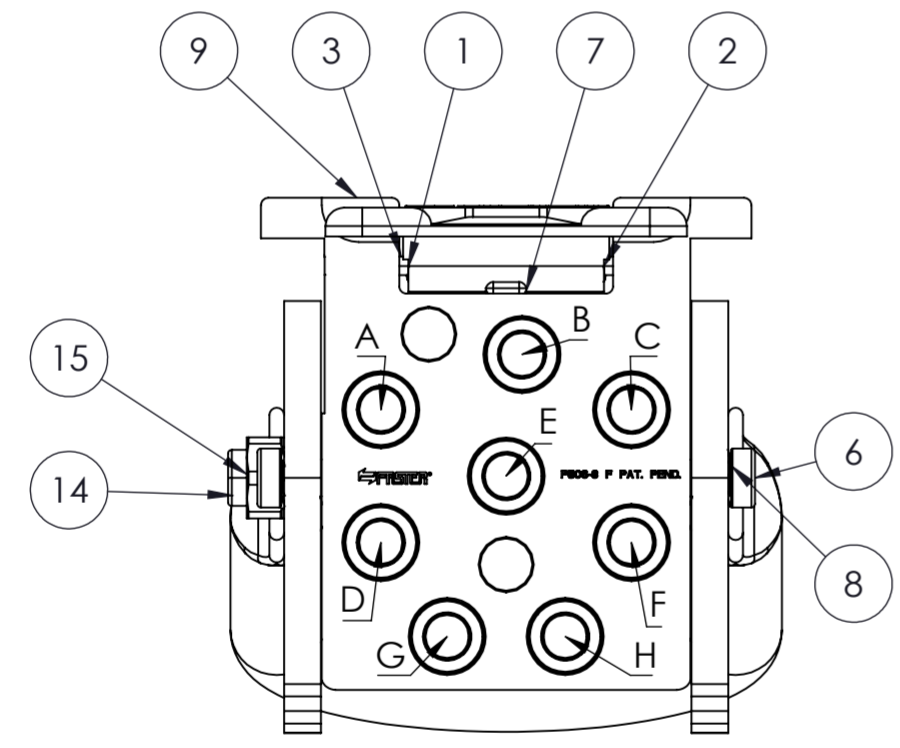
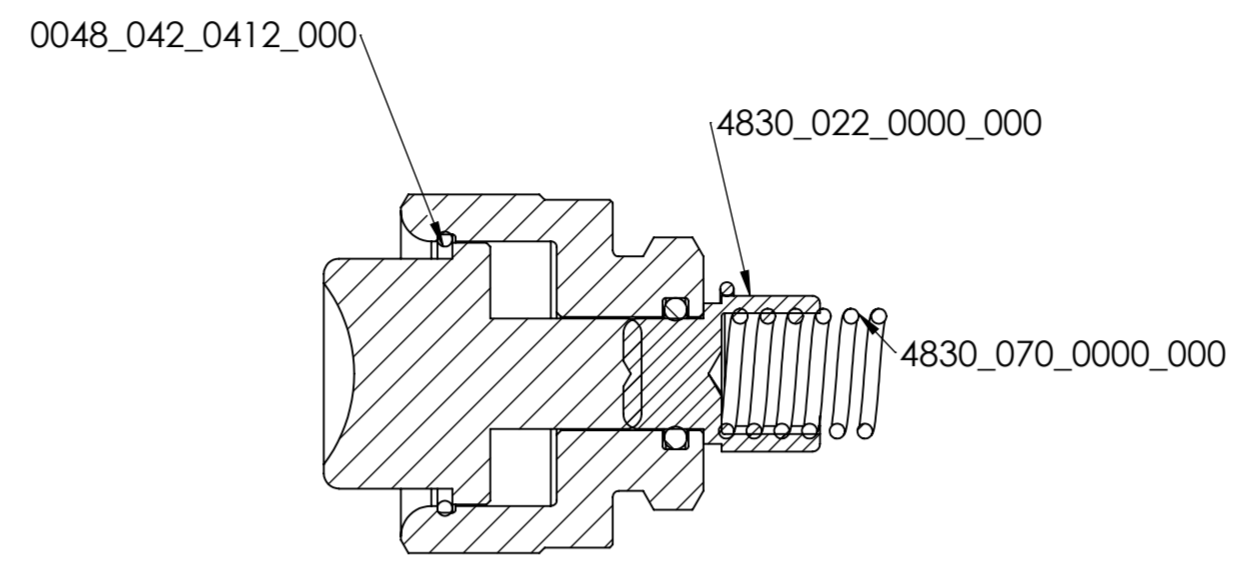
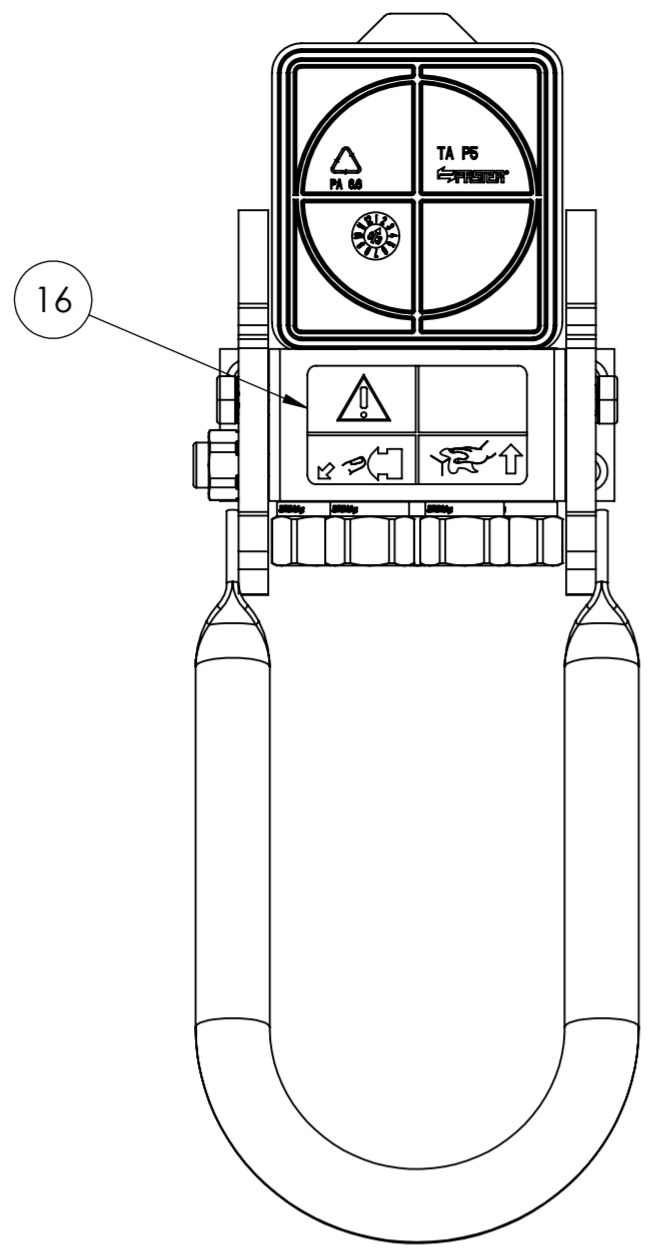

A B C D E F G H

POS.	Q.TY	DESCRIPTION	DRAWING N°	HEX
16	1	STICKER MULTIFASTER SICURA SX	ET011	
15	1	SICURA PER PIASTRA	SICURA	
14	1	ASSIEME LEVA P508	48300245000000	
13	8	GRUPPO INTERNO 06 PER PIASTRA	2FFNB38 GAS F2V	27
12	8	CURSORE ESTERNO 2FFN38.F 2 AIS	41320140000200	
11	1	MOLLA SICURA PIASTRE P4 (KIT SP5)	48300700000000	
10	1	NOTTOLIND SICURA SP4	48300220000000	
9	1	PIASTRA FISSA P506-8 F	48500200000000	
8	2	ANELLO DI COMPENSAZIONE	00483171000000	
7	1	TAPPO MULTIFASTER P506	48100010001014	
6	2	VITE M8X30,5 DEFORMATA A FREDDO	483001330000030	
5	8	MOLLA CURSORE ESTERNO FFH 06	413207200000300	
4	1	ANELLO ELASTICO INTERNO 1/4"	02014150	
3	1	SPINA X TAPPO AUTOMATICO P2	48200010004000	
2	1	MOLLA DESTRA X SUPPORTI/PB06 AISI	48300010005301	
1	1	MOLLA SINISTRA X SUPPORTI/PB06 AISI	48300010005300	

**Faster**

RIVOLTA D'ADDA-CR-ITALY

THIS DRAWING IS EXCLUSIVE PROPERTY OF FASTER S.p.A  
ANY UNAUTHORIZED COPY AND/OR USE ARE STRICTLY PROHIBITED.

DRAWN	CONFIGURATOR	GENERAL TOLERANCES (UNLESS OTHERWISE SPECIFIED): LINEAR DIMENSIONS: 0.1 ANGULAR DIMENSIONS: 10' RADIUS AND CHAMFER: 0.05 SHARP EDGES NOT DIMENSIONED; RADIUS OR CHAMFER MAX. 0.2		DESCRIPTION	MULTIFASTER FIXED PART
DATE	22/08/2024			PART NUMBER	MF-P5068 F-005474-F
SIZE	A2	DIMENSION	SYMBOL		
	DIM. MILLIMETERS	CRITICAL			
		IMPORTANT			
		SECONDARY	NO SYMBOL	DRAWING N°	REVISION
				DB_MF-P5068 F-005474-F	A 10