

FOR NOT SPECIFIED
TIGHTENING TORQUES
SEE NPF 086

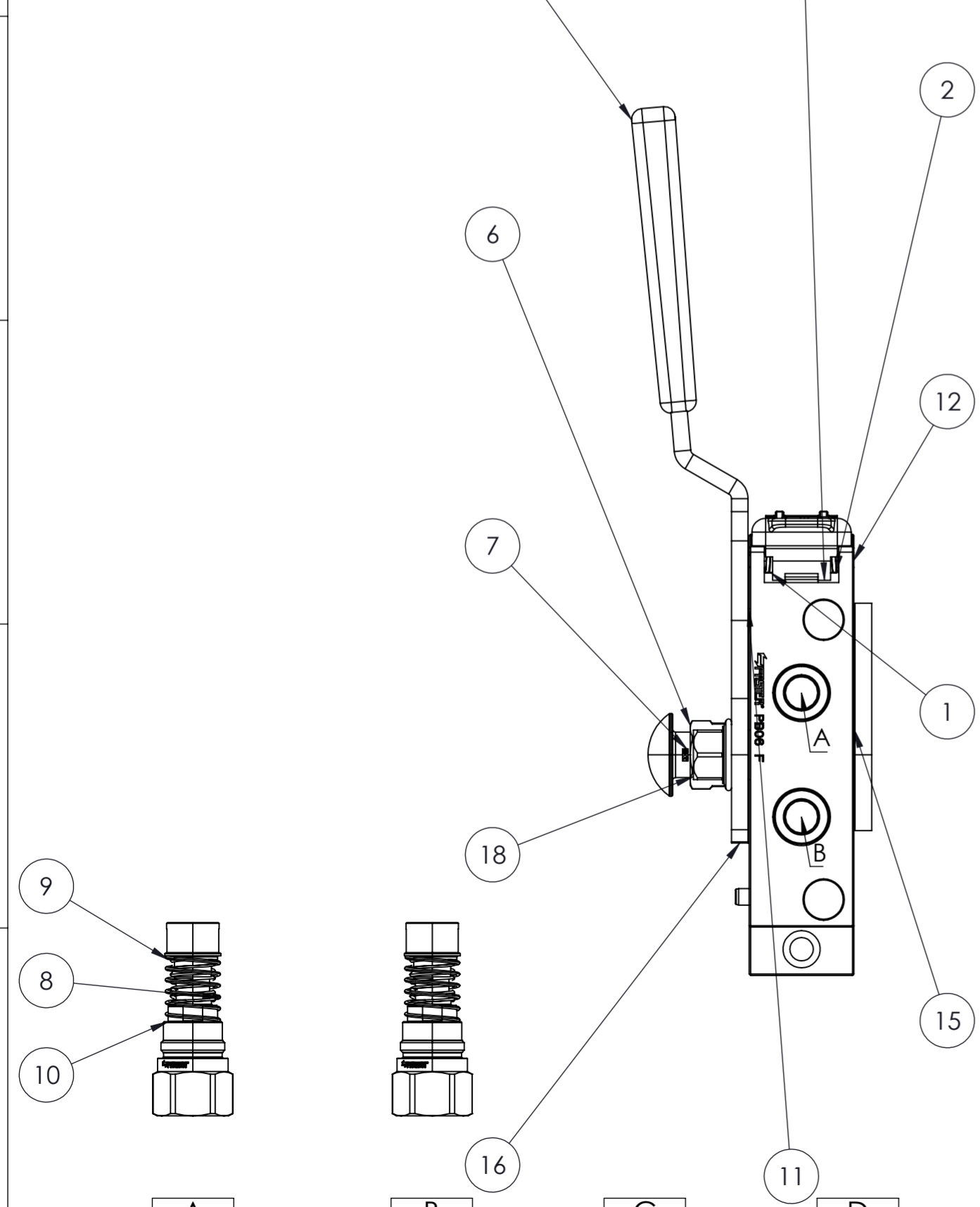
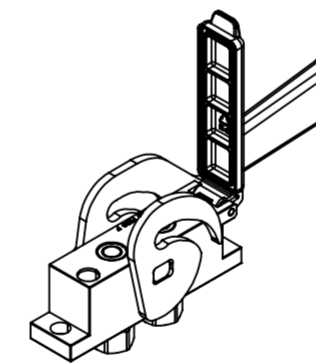
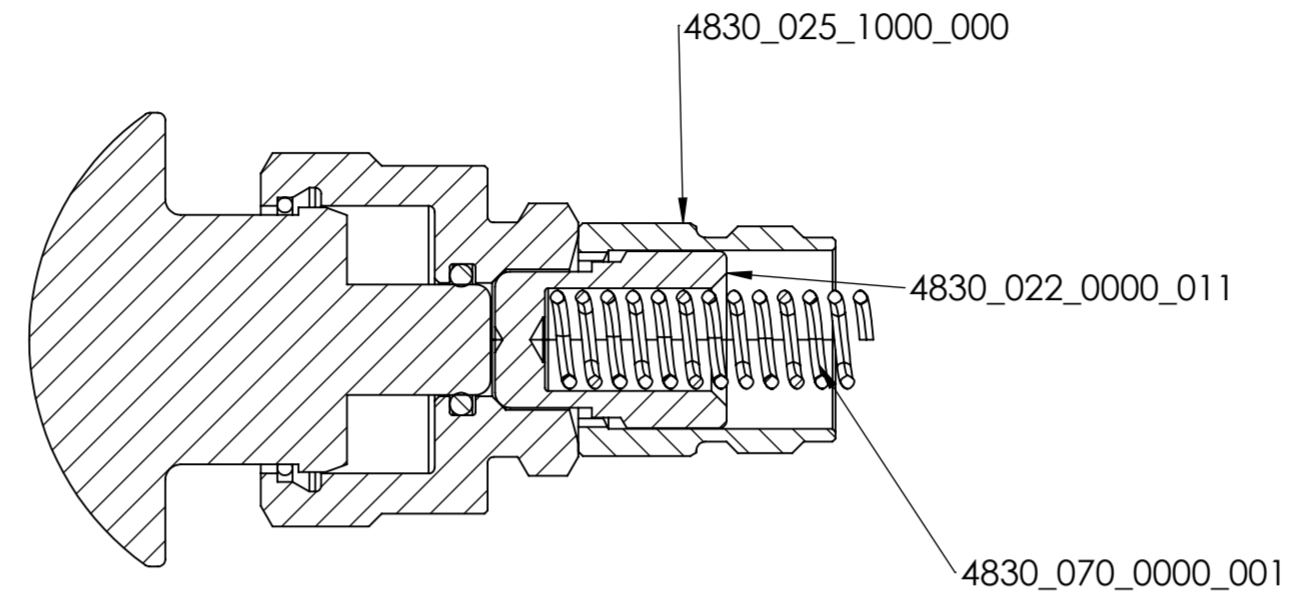
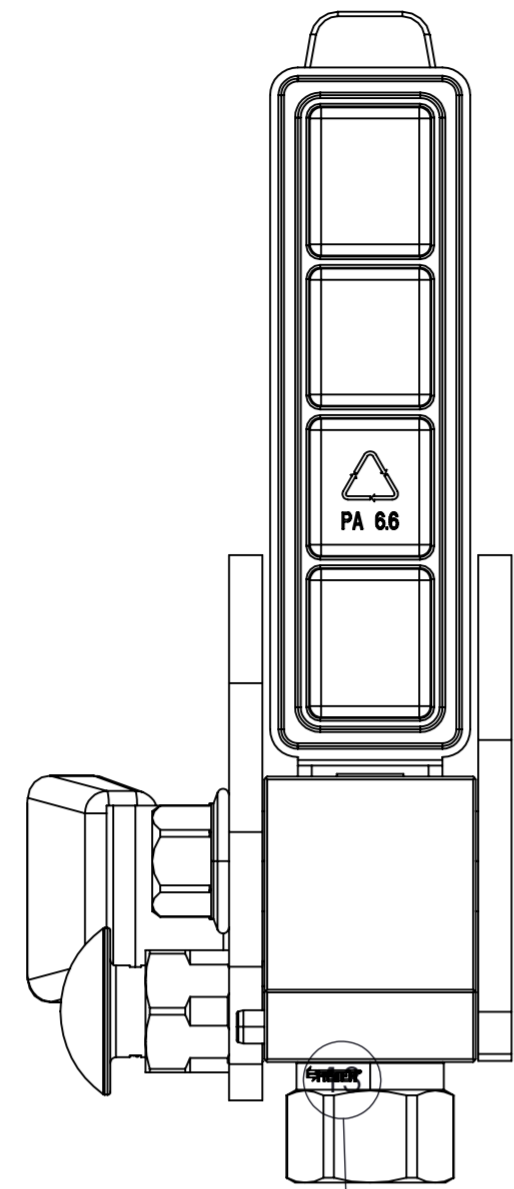

POS.	Q.TY	DESCRIPTION	DRAWING N°	HEX
18	1	DADO AUTOBLOCCANTE M12 ISO 7044	15400800012000	
17	1	MANOPOLA PVC THENAR MOD.1010 30X6	48600240000012	
16	1	CAMMA SINISTRA X LEVA PB06 INVERTIT	48600240001011	
15	1	ASSIEME CAMMA-ALB X PB06 INVERTITA	48600240001001	
14	2	DISTANZIALE PTFE PB06	48500301000000	
13	1	TAPPO MULTIFASTER PB06	48600010001000	
12	1	SPINA X TAPPO AUTOMATICO PB06	48600010003000	
11	1	ASSIEME PIASTRA FISSA PB06+SPINE ST	48600200001001	
10	2	GRUPPO INTERNO 06 PER PIASTRA	2FFNB38-38SAEF	27
9	2	CURSORE ESTERNO 2FFNB38 ACCIAIO	41320140000000	
8	2	MOLLA CURSORE ESTERNO FFH 06	41320720000300	
7	1	PULS SIC DELRIN ROSSO UV RES NEW	48300252000000	
6	1	SICURA NUOVA X PIASTRA P5, ECC.	SICURA P5	
5	1	MOLLA SICURA PIASTRE P5	48300700000001	
4	1	NOTTOLINO SICURA P5 STAMPATO A FREDDO	48300220000011	
3	1	BOCCOLA X NOTTOLINO SICURA P5	48300251000000	
2	1	MOLLA DESTRA X SUPPORTI/PB06 AISI	48300010005301	
1	1	MOLLA SINISTRA X SUPPORTI/PB06 AISI	48300010005300	

Faster

RIVOLTA D'ADDA-CR-ITALY

THIS DRAWING IS EXCLUSIVE PROPERTY OF FASTER S.p.A
ANY UNAUTHORIZED COPY AND/OR USE ARE STRICTLY PROHIBITED.

DRAWN	CONFIGURATOR	GENERAL TOLERANCES (UNLESS OTHERWISE SPECIFIED): LINEAR DIMENSIONS: 0.1 ANGULAR DIMENSIONS: 1° RADIUS AND CHAMFER: 0.05 SHARP EDGES NOT DIMENSIONED; RADIUS OR CHAMFER MAX. 0.2		DESCRIPTION	MULTIFASTER FIXED PART
DATE	22/07/2024			PART NUMBER:	MF-PB06 FS-005350-F
SIZE	A2	DIMENSION	SYMBOL		
	DIM. MILLIMETERS	CRITICAL			
		IMPORTANT			
		SECONDARY	NO SYMBOL	DRAWING N°	REVISION
				DB_MF-PB06 FS-005350-F	A 10