

FOR NOT SPECIFIED
TIGHTENING TORQUES
SEE NPF 086

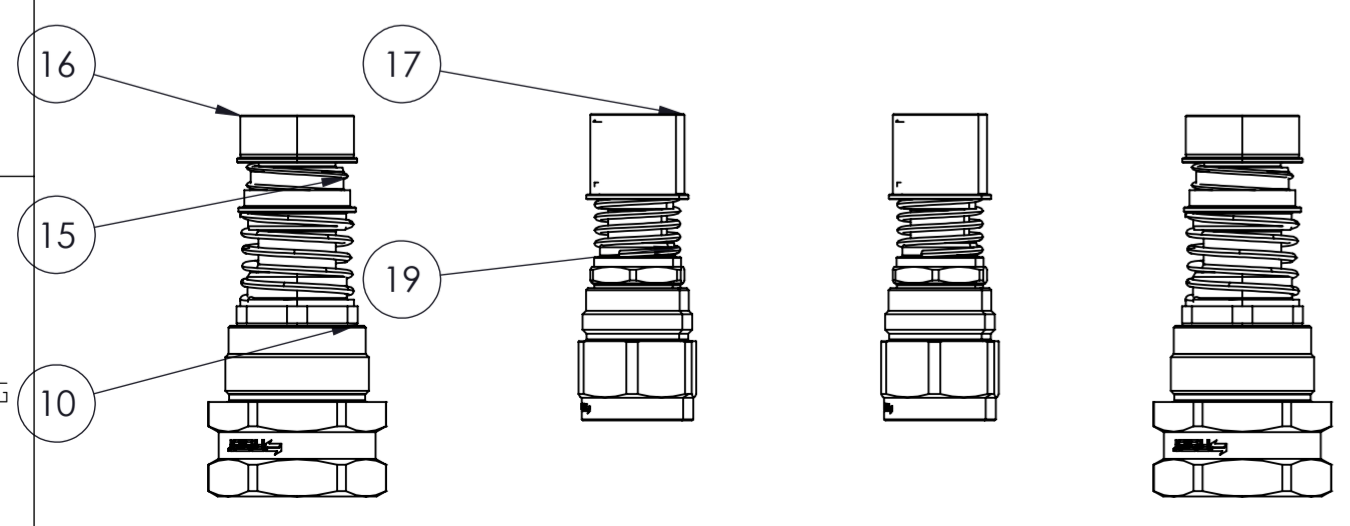
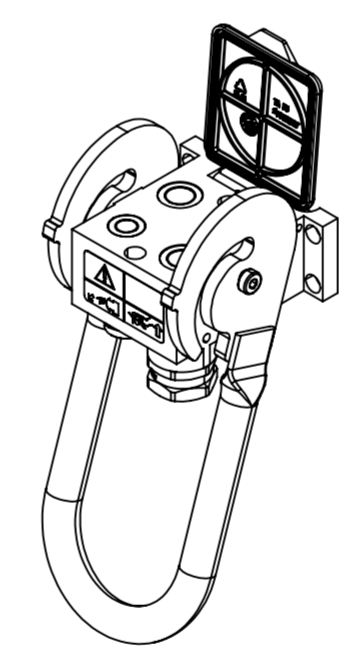
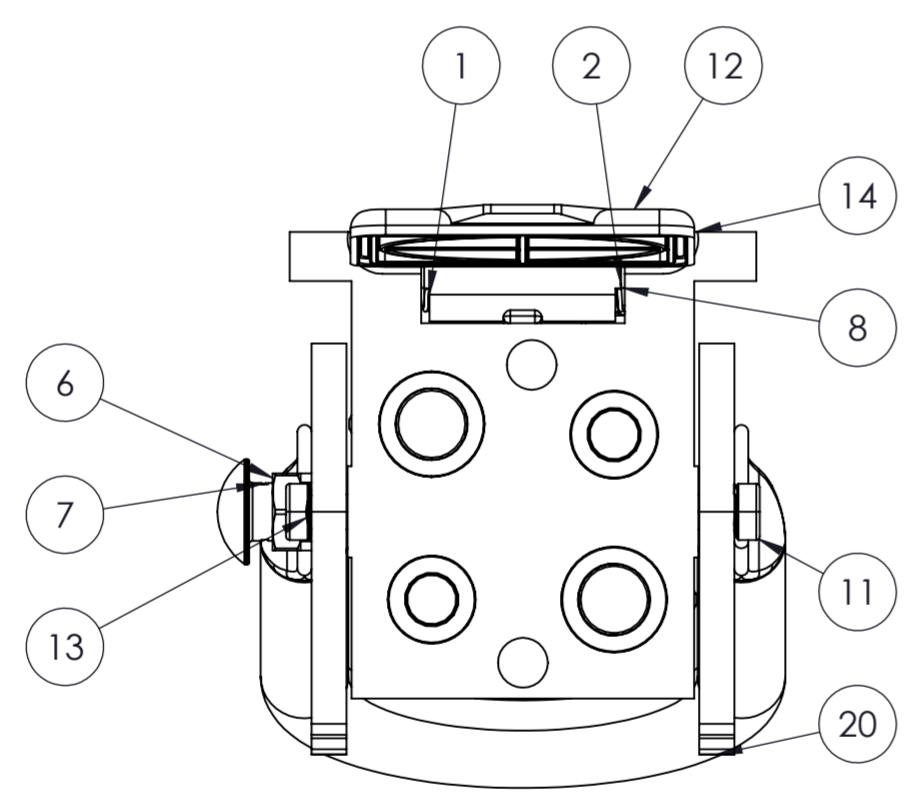
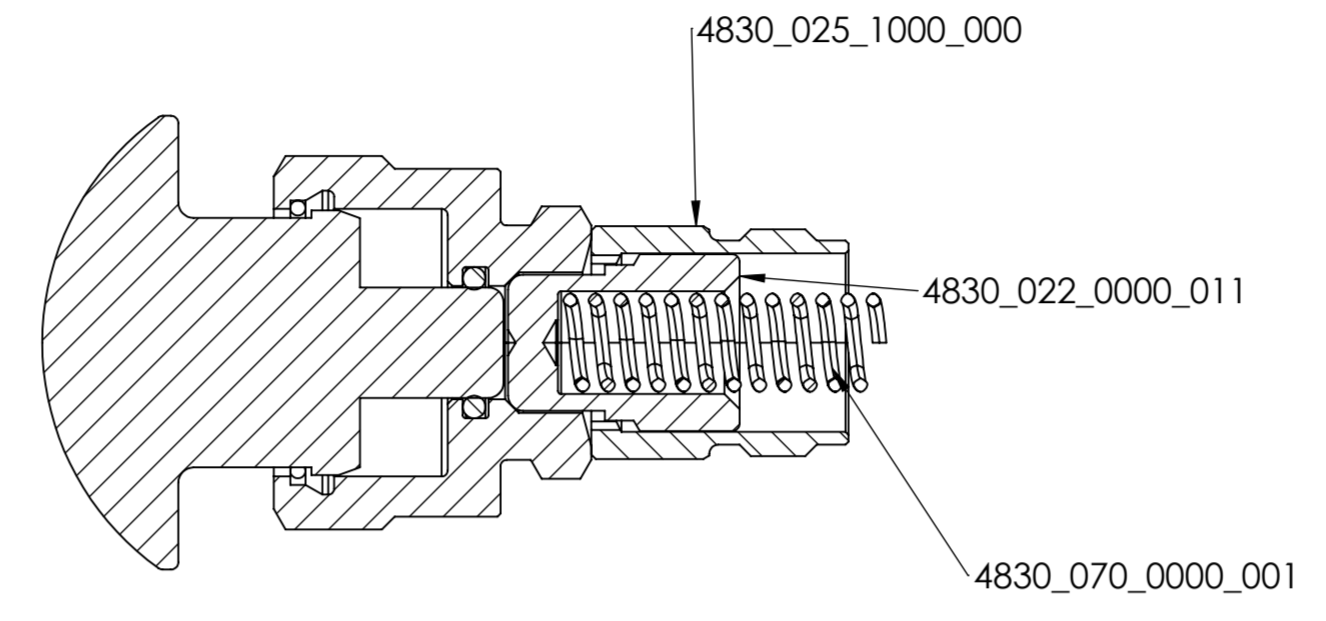
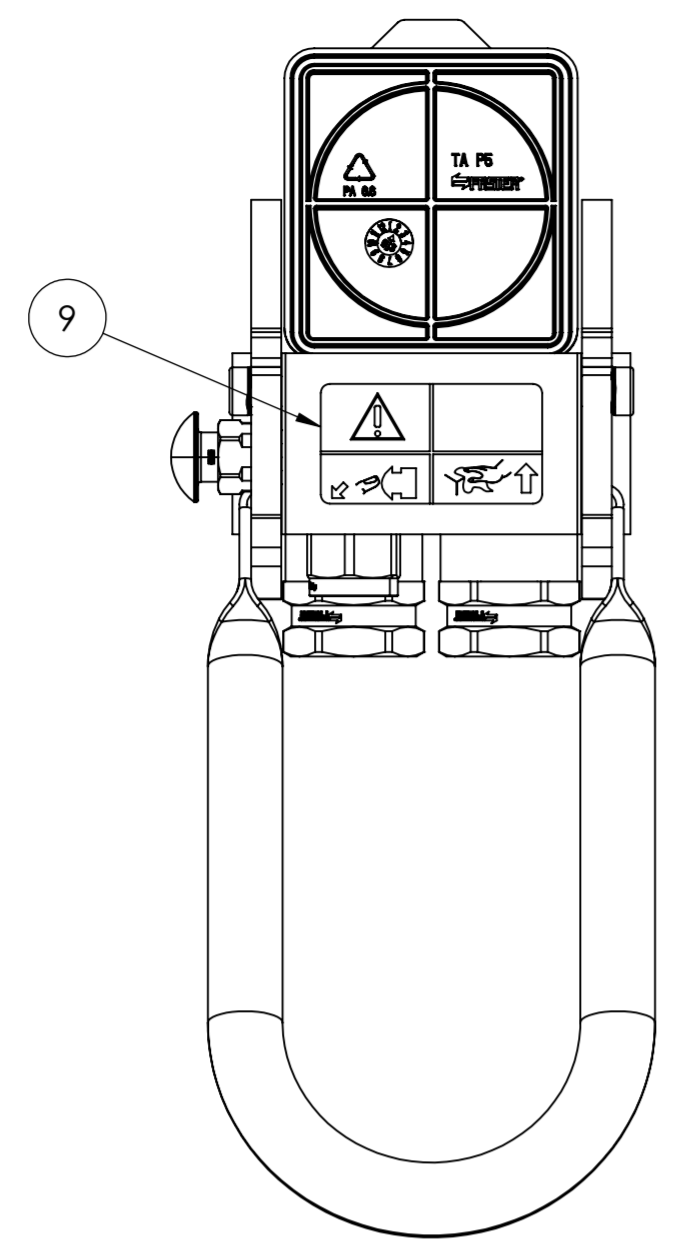

20	1	ASSIEME LEVA P510	48300243000000	
19	2	FEMMINA X BLOCCO 1/2"-3/4" UNF	2FFNB12-12S F	30
18	2	MOLLA CURSORE ESTERNO 2FFN12..F AI	41420721000300	
17	2	CURSORE ESTERNO 2FFNB12 ACCIAIO	43400140000000	
16	2	CURSORE ESTERNO 2FFNB34	42500141000000	
15	2	MOLLA CURSORE ESTERNO FFH 12	41500721000200	-
14	1	PIASTRA FISSA 2P510 F (VITI)	48300200000032	
13	2	ANELLO DI COMPENSAZIONE	00483171000000	
12	1	TAPPO MULTIFASTER P506	48100010001014	
11	2	VITE M8X30,5 DEFORMATA A FREDDO	48300133000030	
10	2	FEMM.X BLOCCO 2FFNB34-3/4"SAE	2FFNB34-34S F	42
9	1	STICKER MULTIFASTER SICURA SX	ET011	
8	1	SPINA X TAPPO AUTOMATICO P2	48200010004000	
7	1	PULS SIC DELRIN ROSSO UV RES NEW	48300252000000	
6	1	SICURA NUOVA X PIASTRA P5, ECC.	SICURA P5	
5	1	MOLLA SICURA PIASTRE P5	48300700000001	
4	1	NOTTOLINO SICURA P5 STAMPATO A FREDDO	48300220000011	
3	1	BOCCOLA X NOTTOLINO SICURA P5	48300251000000	
2	1	MOLLA DESTRA X SUPPORTI/PB06 AISI	48300010005301	
1	1	MOLLA SINISTRA X SUPPORTI/PB06 AISI	48300010005300	
PDS.	Q.TY	DESCRIPTION	DRAWING N°	HEX

Faster

RIVOLTA D'ADDA-CR-ITALY

THIS DRAWING IS EXCLUSIVE PROPERTY OF FASTER S.p.A
ANY UNAUTHORIZED COPY AND/OR USE ARE STRICTLY PROHIBITED.

DRAWN	CONFIGURATOR	GENERAL TOLERANCES (UNLESS OTHERWISE SPECIFIED): LINEAR DIMENSIONS '0.1 ANGULAR DIMENSIONS '1+ RADIUS AND CHAMFER '0.05 SHARP EDGES NOT DIMENSIONED; RADIUS OR CHAMFER MAX. 0.2	DESCRIPTION	MULTIFASTER FIXED PART
DATE	15/12/2023		PART NUMBER :	MF-P510 V F-001356-F
SIZE	A2	DIMENSION	SYMBOL	
	DIM. MILLIMETERS	CRITICAL		
		IMPORTANT		
		SECONDARY	NO SYMBOL	
DRAWING N°			REVISION	
DB_MF-P510 V F-001356-F			A 0	