

FOR NOT SPECIFIED
TIGHTENING TORQUES
SEE NPF 086

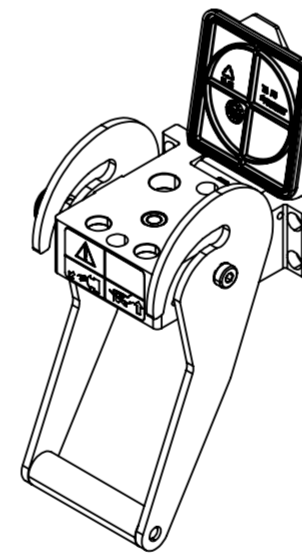
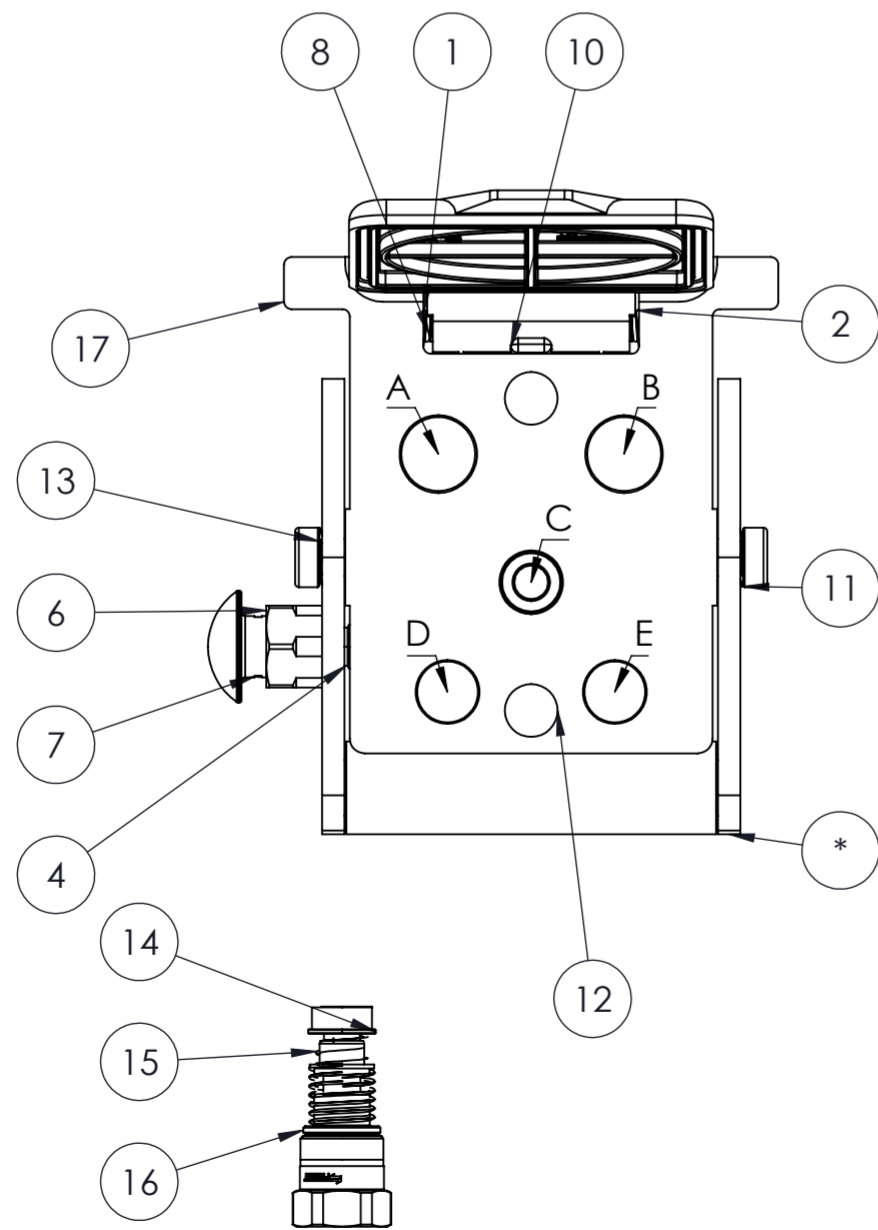
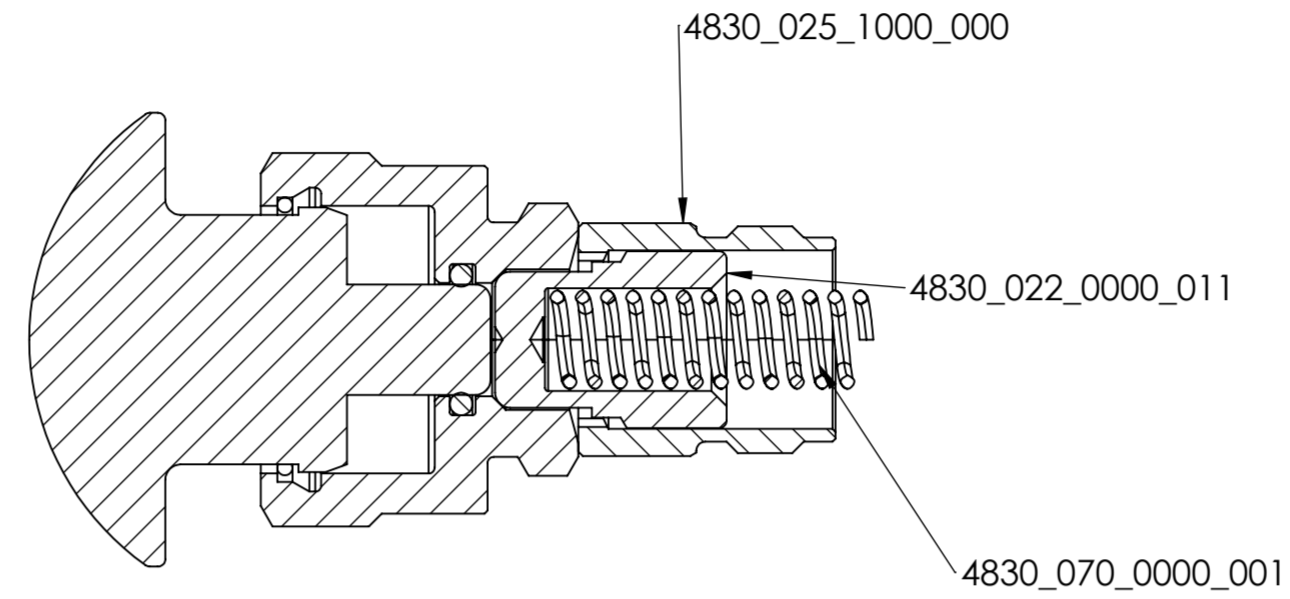
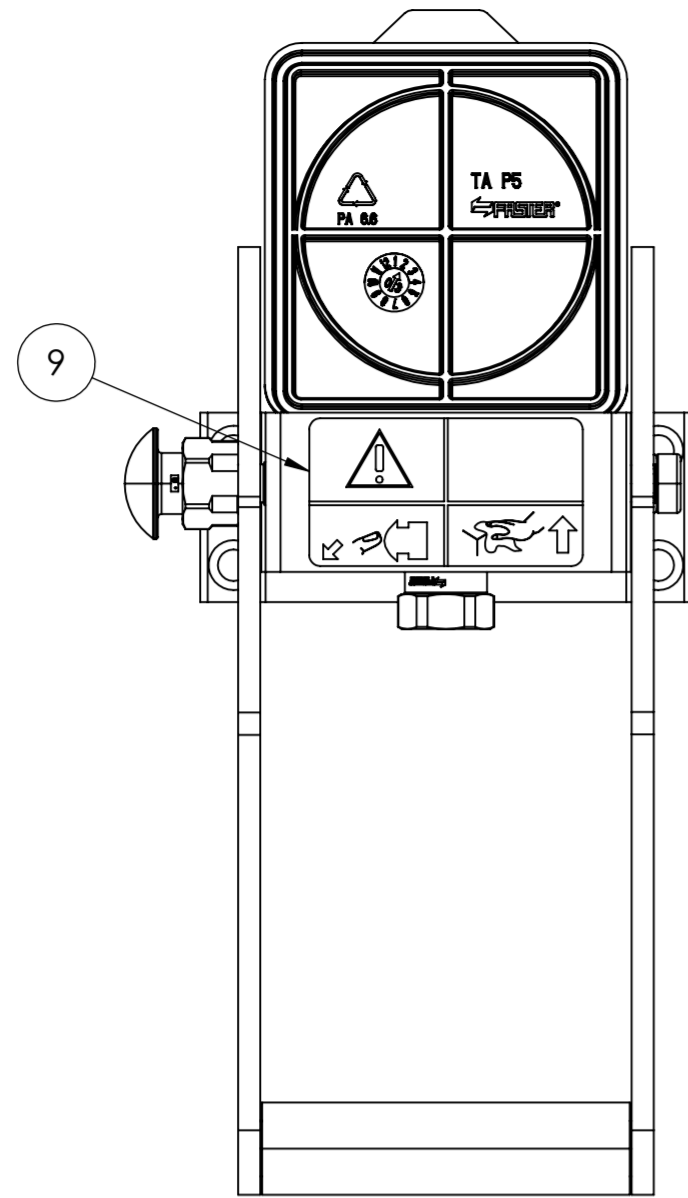

17	1	ASSIEME LEVA P506 SIC SX	48300240003000	
16	1	GRUPPO INTERNO 04 PER PIASTRA	2FFNB14 GAS F	24
15	1	MOLLA CURSORE ESTERNO FFH 04	41210720000200	
14	1	CURSORE ESTERNO 2FFNB14	41210140000000	
13	2	VITE M8X20,5 DEFORMATA A FREDDO	48300133000020	
12	1	PIASTRA FISSA P5065 (DA PRES.FUS)	48300205001000	
11	2	ANELLO DI COMPENSAZIONE	00483171000000	
10	1	TAPPO MULTIFASTER P506	48100010001014	
9	1	STICKER MULTIFASTER SICURA SX	ET011	
8	1	SPINA X TAPPO AUTOMATICO P2	48200010004000	
7	1	PULS SIC DELRIN ROSSO UV RES NEW	48300252000000	
6	1	SICURA NUOVA X PIASTRA P5, ECC.	SICURA P5	
5	1	MOLLA SICURA PIASTRE P5	48300700000001	
4	1	NOTTOLINO SICURA P5 STAMPATO A FREDDO	48300220000011	
3	1	BOCCOLA X NOTTOLINO SICURA P5	48300251000000	
2	1	MOLLA DESTRA X SUPPORTI/PB06 AISI	48300010005301	
1	1	MOLLA SINISTRA X SUPPORTI/PB06 AISI	48300010005300	
POS.	Q.TY	DESCRIPTION	DRAWING N°	HEX

Faster

RIVOLTA D'ADDA-CR-ITALY

THIS DRAWING IS EXCLUSIVE PROPERTY OF FASTER S.p.A
ANY UNAUTHORIZED COPY AND/OR USE ARE STRICTLY PROHIBITED.

DRAWN	CONFIGURATOR	GENERAL TOLERANCES (UNLESS OTHERWISE SPECIFIED): LINEAR DIMENSIONS: 0.1 ANGULAR DIMENSIONS: 1° RADIUS AND CHAMFER: 0.05 SHARP EDGES NOT DIMENSIONED; RADIUS OR CHAMFER MAX. 0.2	DESCRIPTION	MULTIFASTER FIXED PART
DATE	03/08/2022		PART NUMBER :	MF-P5065 F-004345-F
SIZE	A2	DIMENSION	SYMBOL	
	DIM. MILLIMETERS	CRITICAL	⊕	
		IMPORTANT	⊕	
		SECONDARY	NO SYMBOL	
			DRAWING N°	DB_MF-P5065 F-004345-F
			REVISION	A 0