

FOR NOT SPECIFIED  
TIGHTENING TORQUES  
SEE NPF 086

LUBRICATE WITH " MOLY-TEF "  
THE COMPONENT : N° 19

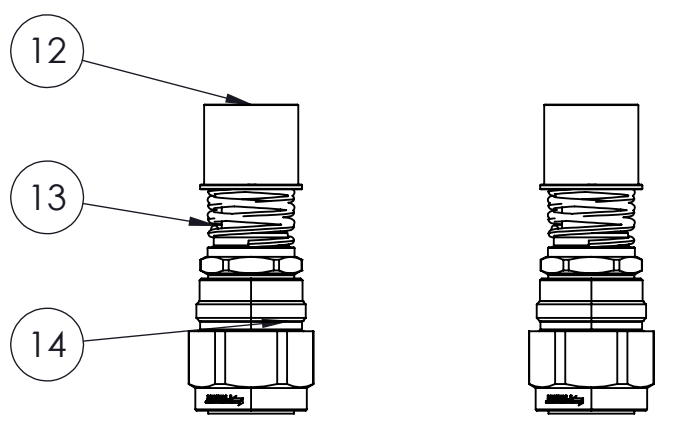
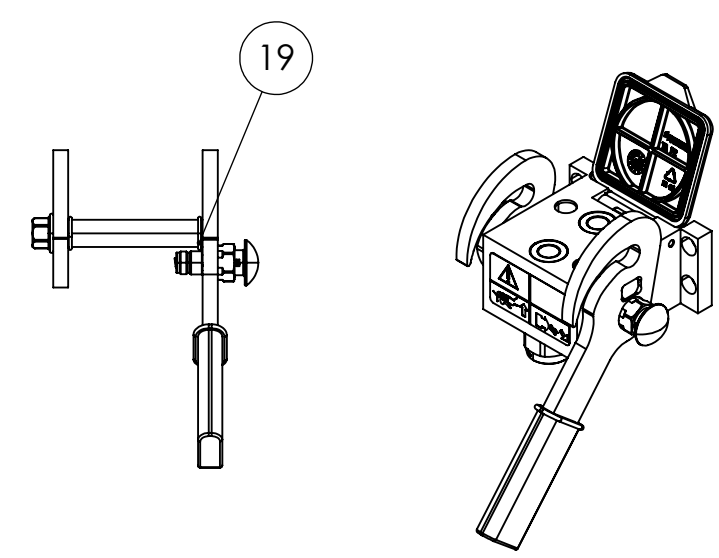
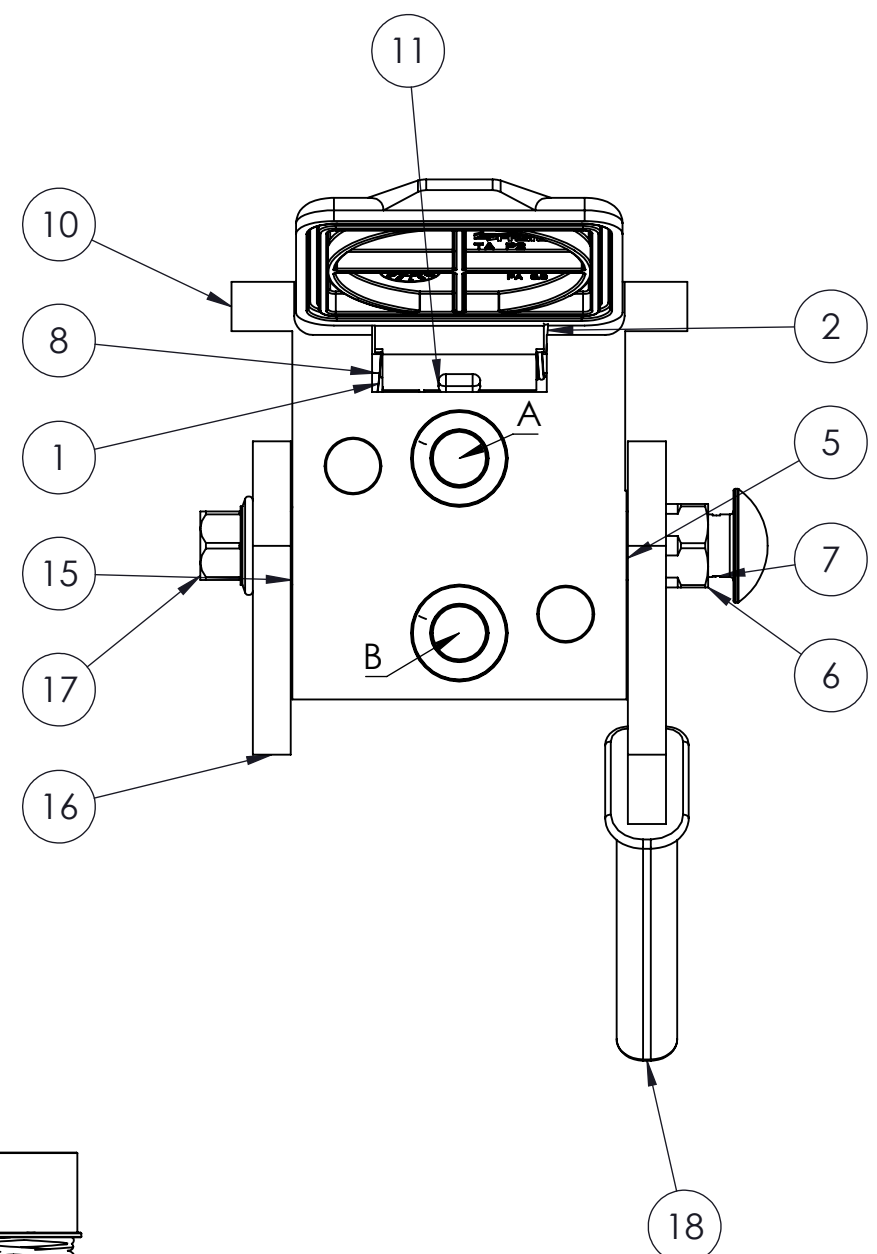
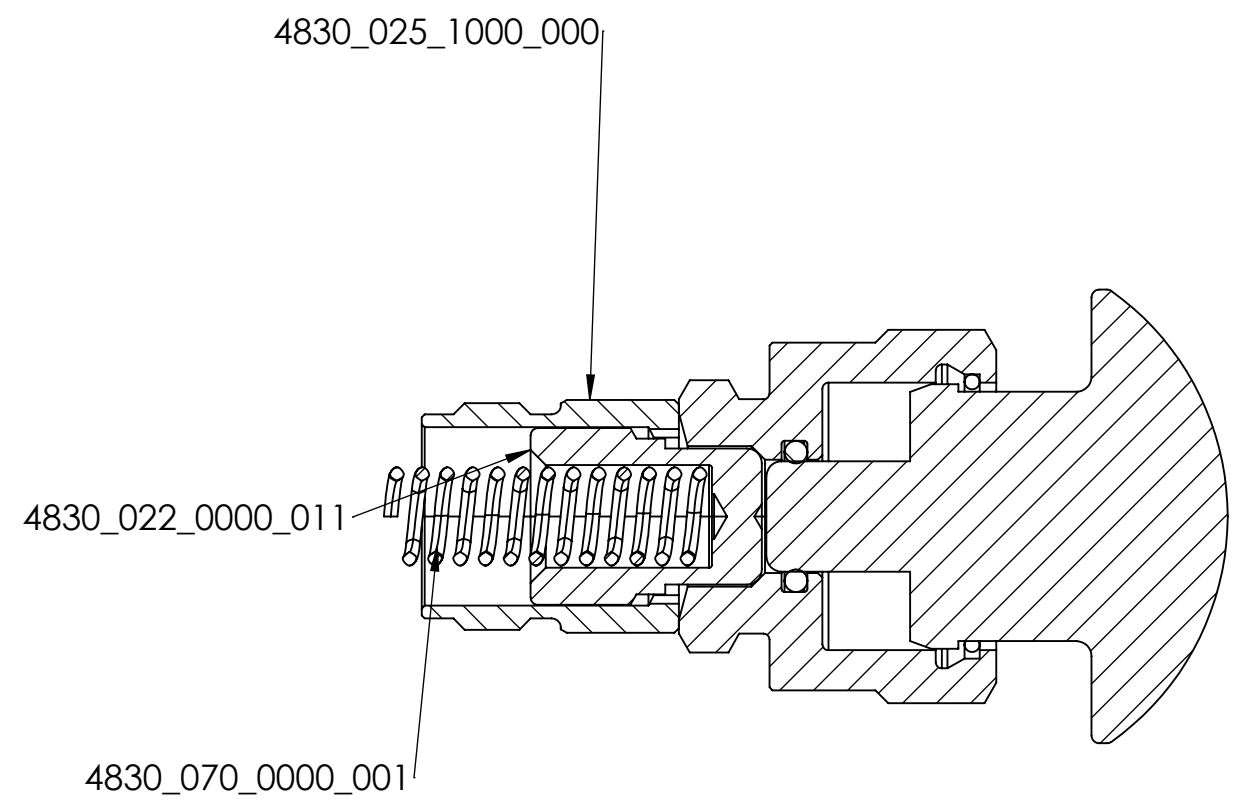
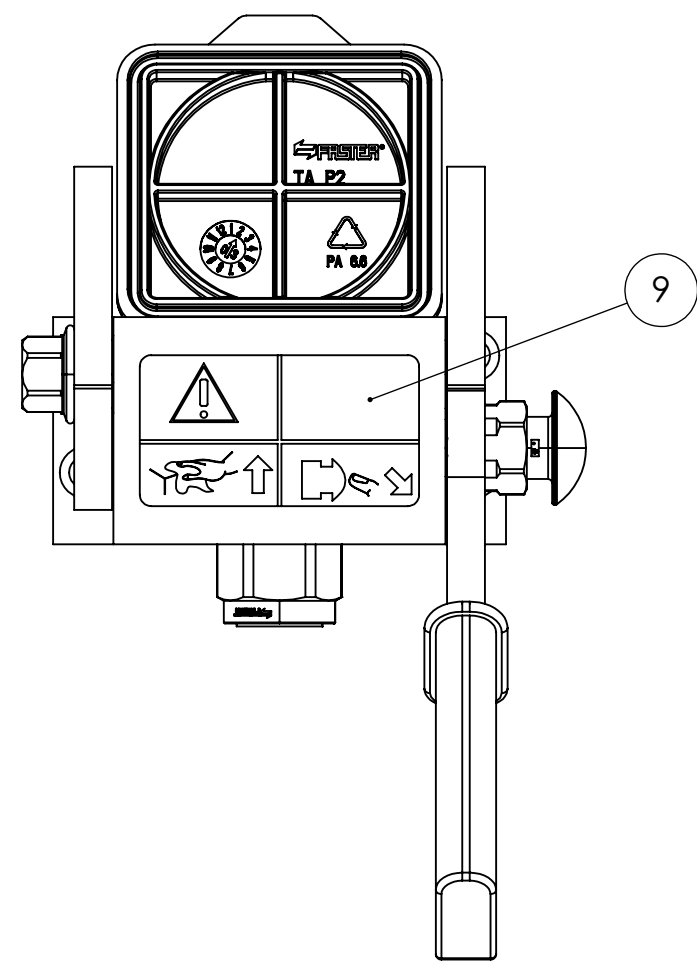

POS.	Q.TY	DESCRIPTION	DRAWING N°	HEX
19	2	OR NITRILE 80° SHORE	OR 2x18	
18	1	MANDPOLA PVC THENAR MOD.1020 30X10	48300240001012	
17	1	DADD AUTOBLOCCANTE M12 ISO 7044	15400800012000	
16	1	CAMMA DESTRA/SINISTRA P208 F	48200241001020	
15	1	ASSIEME LEVA SX 3P208 F KUBOTA	48200241012000	
14	2	FEMMINA X BLOCCO 2FFNB13	2FFNB12 GAS F	30
13	2	MOLLA CURSORE ESTERNO 2FFN12.F AI	41420721000300	
12	2	CURSORE ESTERNO 2FFNB12 ACCIAIO	43400140000000	
11	1	TAPPO MULTIFASTER P208	48200010001004	
10	1	PIASTRA FISSA 2P208 F (ALBERO)	48200201000021	
9	1	STICKER MULTIFASTER SICURA DX	ET012	
8	1	SPINA X TAPPO AUTOMATICO P2	48200010004000	
7	1	PULS SIC DELRIN ROSSO UV RES NEW	48300252000000	
6	1	SICURA NUOVA X PIASTRA P5, ECC.	SICURA P5	
5	1	MOLLA SICURA PIASTRE P5	48300700000001	
4	1	NOTTOLINO SICURA P5 STAMPATO A FREDDO	48300220000011	
3	1	BOCCOLA X NOTTOLINO SICURA P5	48300251000000	
2	1	MOLLA DESTRA X SUPPORTI/PB06 AISI	48300010005301	
1	1	MOLLA SINISTRA X SUPPORTI/PB06 AISI	48300010005300	

RIVOLTA D'ADDA-CR-ITALY

THIS DRAWING IS EXCLUSIVE PROPERTY OF FASTER S.p.A  
ANY UNAUTHORIZED COPY AND/OR USE ARE STRICTLY PROHIBITED.

DRAWN	CONFIGURATOR	GENERAL TOLERANCES (UNLESS OTHERWISE SPECIFIED): LINEAR DIMENSIONS: ±0.1 ANGULAR DIMENSIONS: ±1° RADIUS AND CHAMFER: ±0.05 SHARP EDGES NOT DIMENSIONED; RADIUS OR CHAMFER MAX. 0.2	DESCRIPTION
DATE	04/08/2021		MULTIFASTER FIXED PART
SIZE	A2	DIMENSION	PART NUMBER :
	DIM. MILLIMETERS	CRITICAL	MF-P208 F-000763-F
		IMPORTANT	DRAWING N°
		SECONDARY	DB_MF-P208 F-000763-F
			REVISION
			A   0

A  
B  
C  
D  
E  
F  
G

A  
B  
C  
D  
E  
F  
G